



ALL-NEW 2027  
QX65



↓ SWIPE

# Jump to a Section

Tap An Arrow To Skip To Section

---

## Design

Exterior, Interior, Space & Cargo

---



## Onboard Tech

Comfort & Convenience, Infotainment

---



## Performance & Drive Tech

Performance, Driver Assist Technology

---



## Style & Specs

Style, Specs, Trims

---



## Accessories

Exterior, Interior, Cargo, Lighting/Tech,  
Towing, Pet



**IMPORTANT VEHICLE INFORMATION**

# Design

Exterior



---

Interior



---

Space & Cargo



---

Back to Menu



Build & Price →

UNAPOLOGETIC DESIGN

# Reward Yourself With Distinction



BACK TO SECTION

**UNAPOLOGETIC DESIGN**

Your next chapter deserves a vehicle as bold as your vision. Every curve channels energy, every angle declares confidence. This is a vehicle engineered for those who refuse to blend in, and whose next chapter demands a machine as distinguished as they are. **Inspired by the iconic INFINITI FX**, a vehicle that gave definition to the crossover, is the **First-Ever 2027 INFINITI QX65. All-new, bold and rewarding**, we introduce this **sporty crossover**, ready to redefine the next generation of mobility.



Powerful, sleek silhouette



All-New sporty Crossover design

**UNAPOLOGETIC DESIGN**

Before you even reach the door, the QX65 graciously welcomes you. A striking available **INFINITI Light Path** casts an illuminating glow upon the ground, while the **Welcome Lighting** blinks to greet you. Every sparkling, precision engineered LED serves a purpose – to enhance visibility in low light and announce your presence with grace.

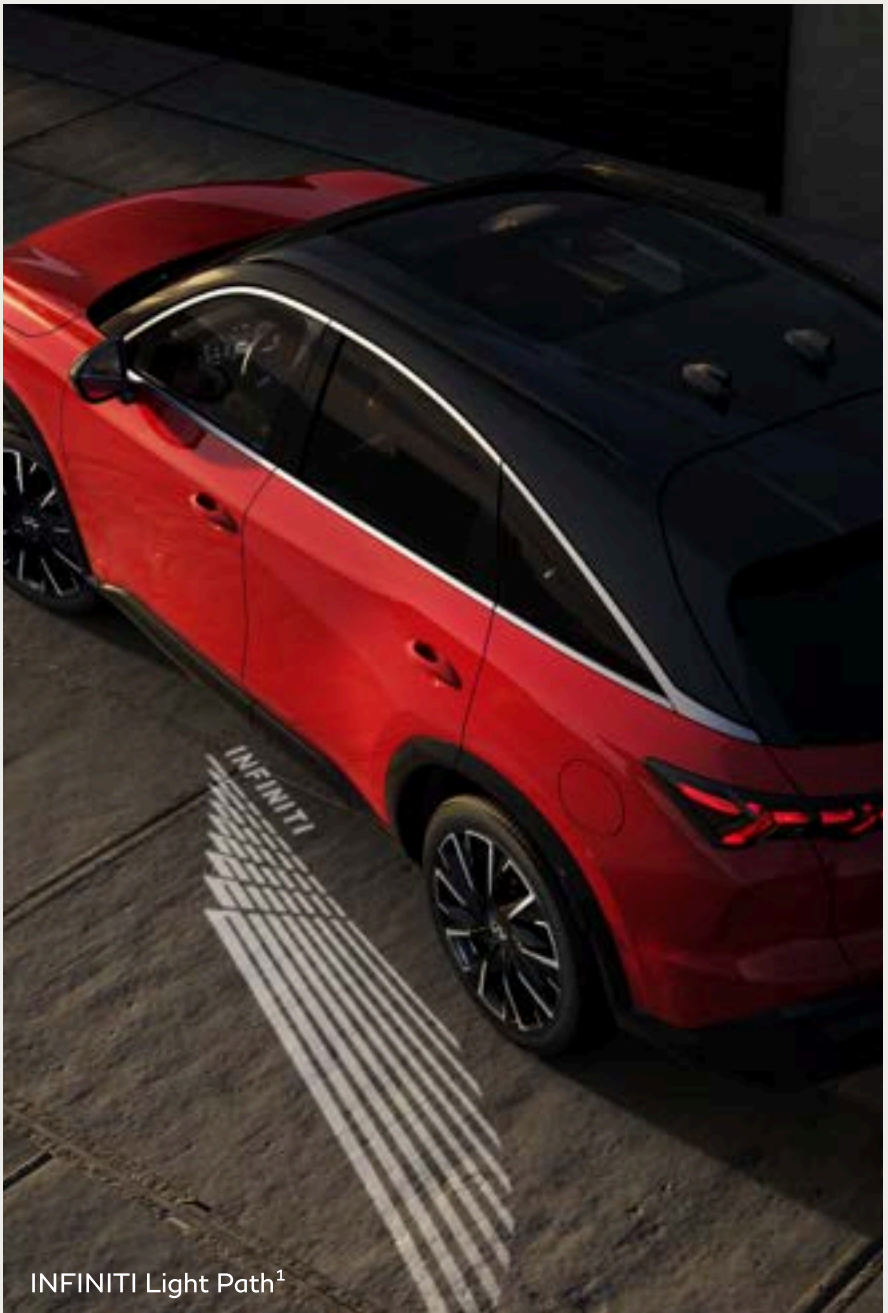
INFINITI Light Path<sup>1</sup>

## UNAPOLOGETIC DESIGN

The QX65 commands presence in an exclusive **supercar-inspired Sunfire Red** exterior paint. What truly distinguishes it is the **TriCoat with gold-coated flecks**,<sup>2</sup> a luxury finish that shifts and gleams with movement. Real gold-coated flecks catch light and attention like a personal statement, transforming the look of the paint color under the morning sun or during sunset drives.



Sunfire Red Pearl Metallic exterior paint<sup>2</sup>

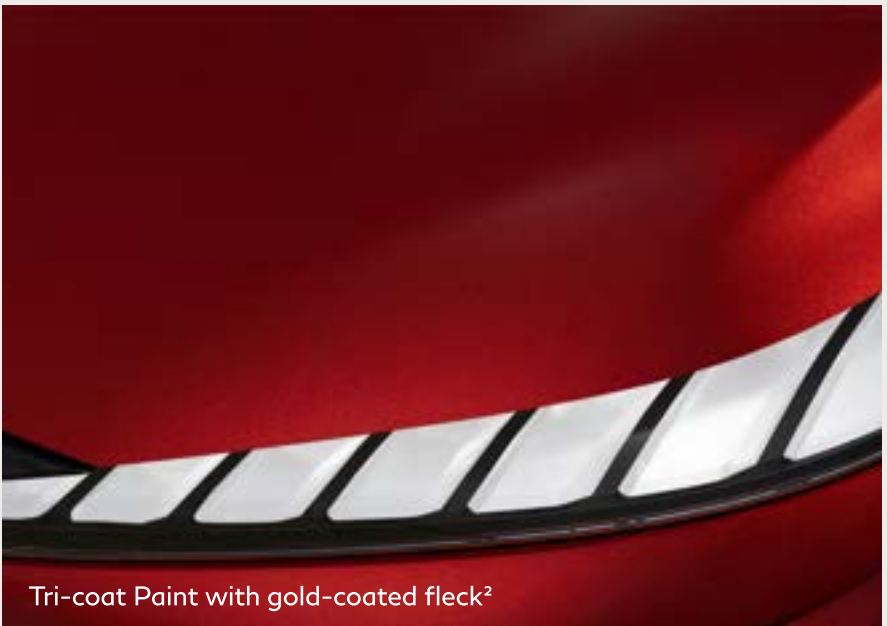

Tri-coat Paint with gold-coated fleck<sup>2</sup>

**UNAPOLOGETIC DESIGN**

Grip the road with tactical confidence and dynamic control with **Large 21-inch wheels**.<sup>1</sup> Expect superior grip and responsive steering thanks to their size. Heightened stability helps deliver a smoother ride over bumps, cracks and everyday surfaces. It's another way intentional design ensures a commanding presence.



Large 21" machined aluminum-alloy wheels<sup>1</sup>

QX65

Exterior

FRONT DESIGN CUES

# Lead With a Powerful Presence



## FRONT DESIGN CUES

The QX65 announces itself through a striking **Sport grille mesh insert**<sup>1</sup> that resembles a bamboo forest in a storm. It is strong, sculptural, and unapologetically bold. This design channels raw energy down the shoulder line, making the vehicle feel alive before the engine even awakens. At the center of the grille, an **Illuminated three-dimensional emblem** pulls you in, symbolizing new experiences on the horizon.



Sport Grille Mesh Insert

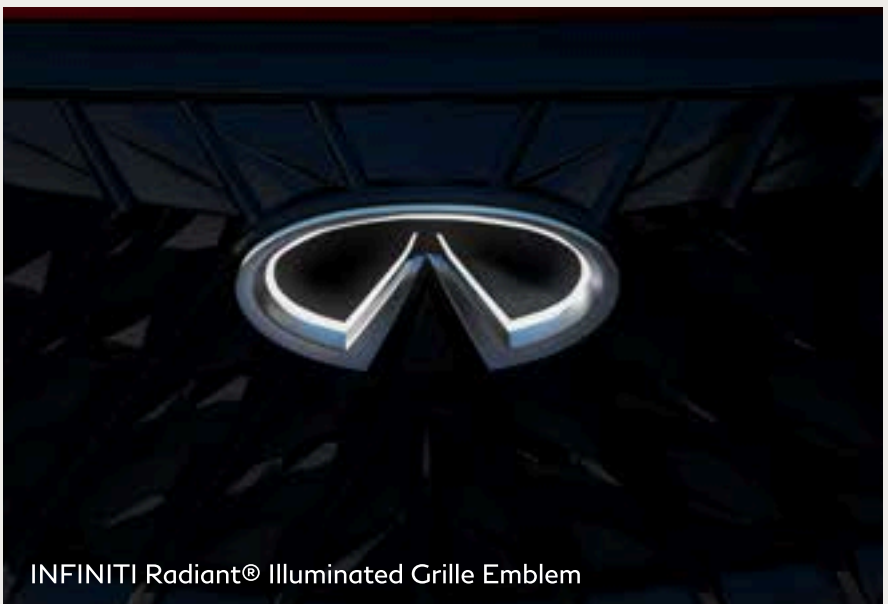

INFINITI Radiant® Illuminated Grille Emblem

## FRONT DESIGN CUES

From every angle, the QX65 communicates power. The lines of the muscular **sculpted hood** rise with purpose, catching light and revealing shadow. Below, a uniquely designed **front bumper** frames sporty and aggressive air intakes. These aren't decorative flourishes; they're intentional design choices that transform the front view into a portrait of refined power.



Sculpted Hood Design

## FRONT DESIGN CUES

Flanking the centerpiece are **LED Daytime Running Lights** with **signature Digital Piano Keys**. These lights have automatic on/off functionality, and they feature an intricate kimono-fold pattern, marrying advanced illumination technology with cultural artistry.



Digital Piano Key DRLs



LED automatic on/off headlights

QX65

Exterior

REAR DESIGN CUES

Designed To Cut  
Through Convention



## REAR DESIGN CUES

The QX65 writes a new chapter in the INFINITI playbook by drawing inspiration from the iconic FX that defined the crossover segment. The **shooting brake roofline** tapers elegantly, **pinching at the D-pillar** to create a fastback silhouette. **Seamless glass and metal integration** flow without interruption. The result is a vehicle that looks like it's cutting through air even when standing still.



Shooting brake roofline

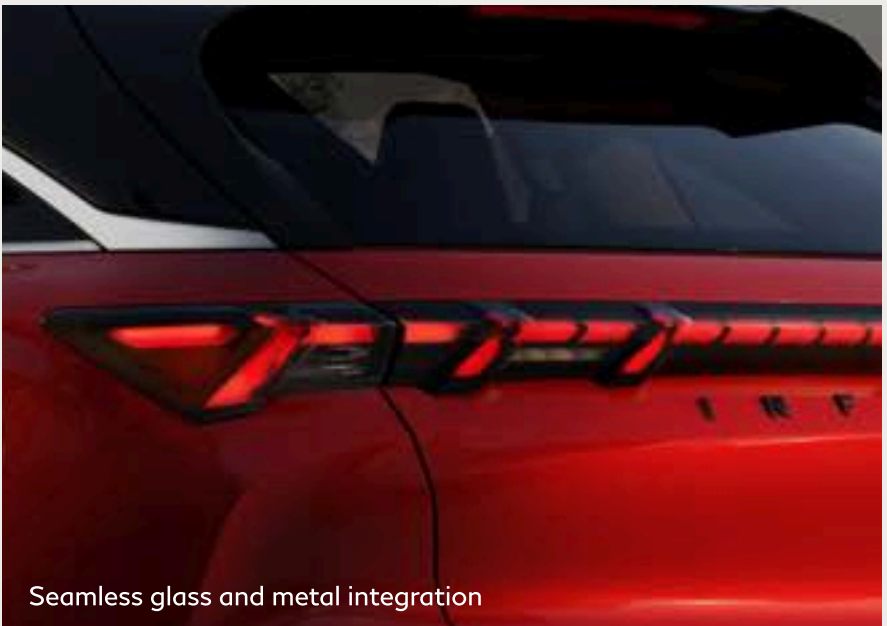

Seamless glass and metal integration

**REAR DESIGN CUES**

The long, straight hood carries through from the vehicle's **shoulder line** to create a striking visual statement. The profile further projects a sleek sense of motion. **Sculpted quarter panels** broaden the stance into a confident, wide-body silhouette and create an athletic posture.



Sculpted quarter panels

## REAR DESIGN CUES

A **protruding rear end** announces authority with uncompromising boldness. The **three-dimensional LED taillights** mimic the tail fin of a jet aircraft, translating performance into art. Above sits an **aerodynamic rear spoiler and hidden wiper**. Form and function merge into one fluid gesture.



Three-dimensional LED taillights

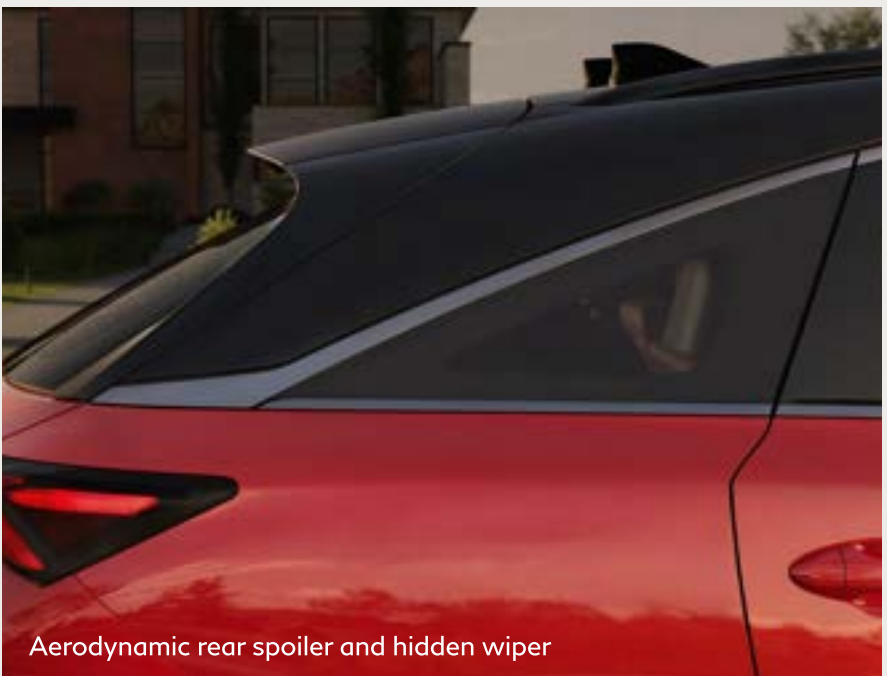

Aerodynamic rear spoiler and hidden wiper

QX65

Interior

INDULGENT INTERIOR DESIGN

Every Line Is  
a Statement



**INDULGENT INTERIOR DESIGN**

The **ultra-comfort cabin** welcomes you with refined proportions designed for presence.

**Integrated air vents** disappear into the architecture. **Blacked-out haptic controls** respond to your touch with precision.

A **seamless floating long console** anchors the cabin, crowned by an elegant **leather-accented shifter** that transforms gear selection into a gesture of control. Every detail has been considered, and every surface crafted to satisfy.



**INDULGENT INTERIOR DESIGN**

Your cabin, your rules. The **Enhanced multi-color ambient interior lighting**<sup>1</sup> offers 64 unique color selections based on the Japanese seasons that reflect delicate changes in nature. The color you select, like Yellow Sun from the spring collection, will save to your fob. Each time you start the QX65, the color will light up<sup>1</sup> the cabin.



Enhanced multi-color ambient interior lighting<sup>1</sup>



64 color options including 16 INFINITI Themed Colors<sup>1</sup>

## INDULGENT INTERIOR DESIGN

It takes a trained eye to notice the subtle details of true craftsmanship, though all will immediately feel its powerful effects. **Quilted semi-aniline leather appointments<sup>1</sup>** are smooth to the touch and offer extreme comfort.

**Contrast stitching** weaves through the dash, console and armrests, creating distinction in the smooth leather. **Soft-touch materials<sup>1</sup>** surround and natural **Black Open Pore Ash Wood<sup>1</sup>** anchors it all.



Quilted semi-aniline leather appointments<sup>1</sup>

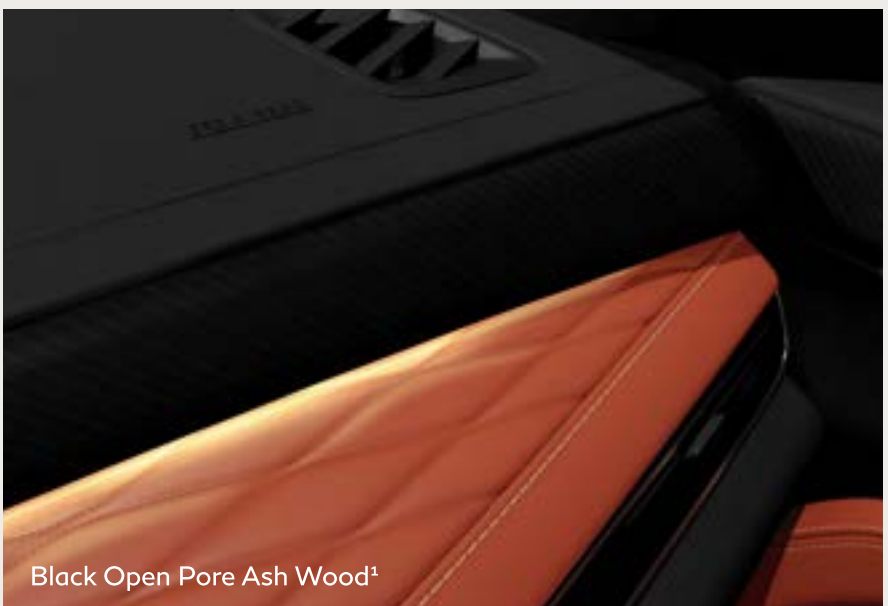

Black Open Pore Ash Wood<sup>1</sup>

QX65

Space & Cargo

SPACIOUS INTERIOR

# Curate Your Comfort



## SPACIOUS INTERIOR

The QX65 is engineered for the best chapter of your life with room for **up to five passengers** and infinite possibilities. The **1st-row roominess** lets you command the road with presence and ease. The theatre-style seating ensures everyone enjoys an elevated view on scenic drives. **Reclining and sliding second-row seats** adapt to your needs. Recline for longer trips or slide the seats forward for increased cargo space.<sup>3,4</sup> Every configuration reflects how you live including the **60/40 split folding rear seats** that accommodate both cargo and a rear passenger.



Five-passenger seating with second-row bench seating

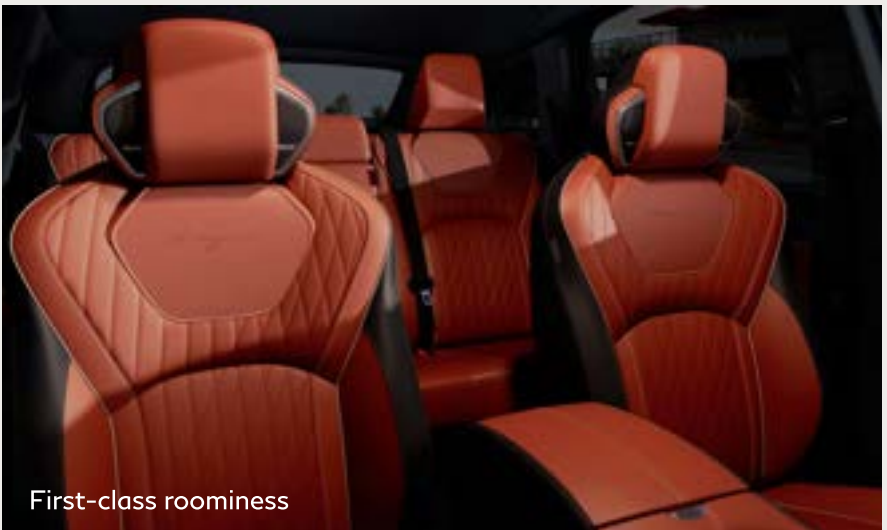

First-class roominess

**SPACIOUS INTERIOR**

The **standard panoramic moonroof** stretches across the roofline with power sliding and tilt functionality, flooding the cabin with natural light and creating an open, airy atmosphere. An electric roof sunshade gives you control over the light and warmth whenever you need it. Your cabin becomes a place to connect with the beauty of nature.

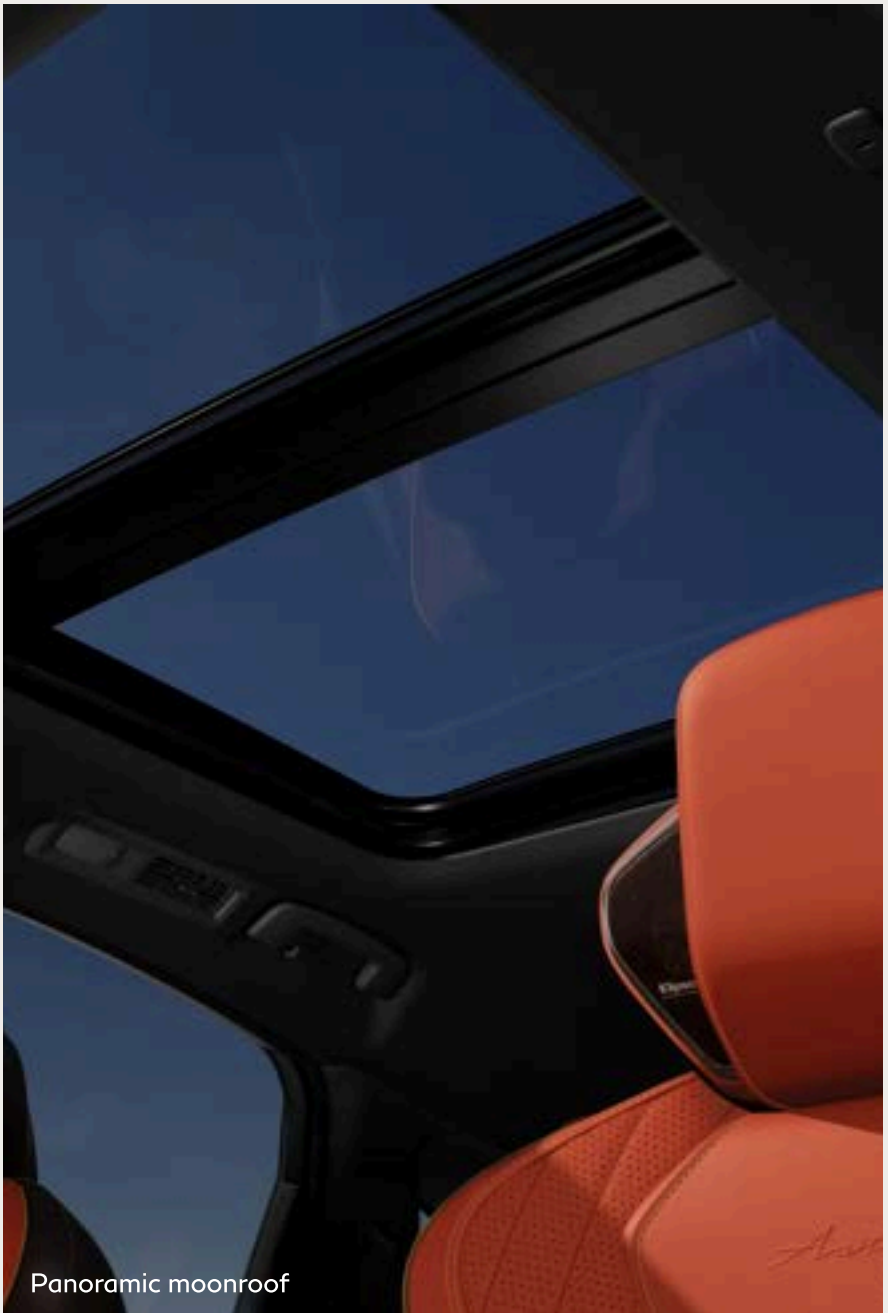

Panoramic moonroof

**SPACIOUS INTERIOR**

Simplify your daily routine. With a swift kicking motion under the center of the rear bumper, the **Motion-Activated Liftgate** opens up to the cargo space, allowing easy access even when your hands are full.<sup>1</sup>

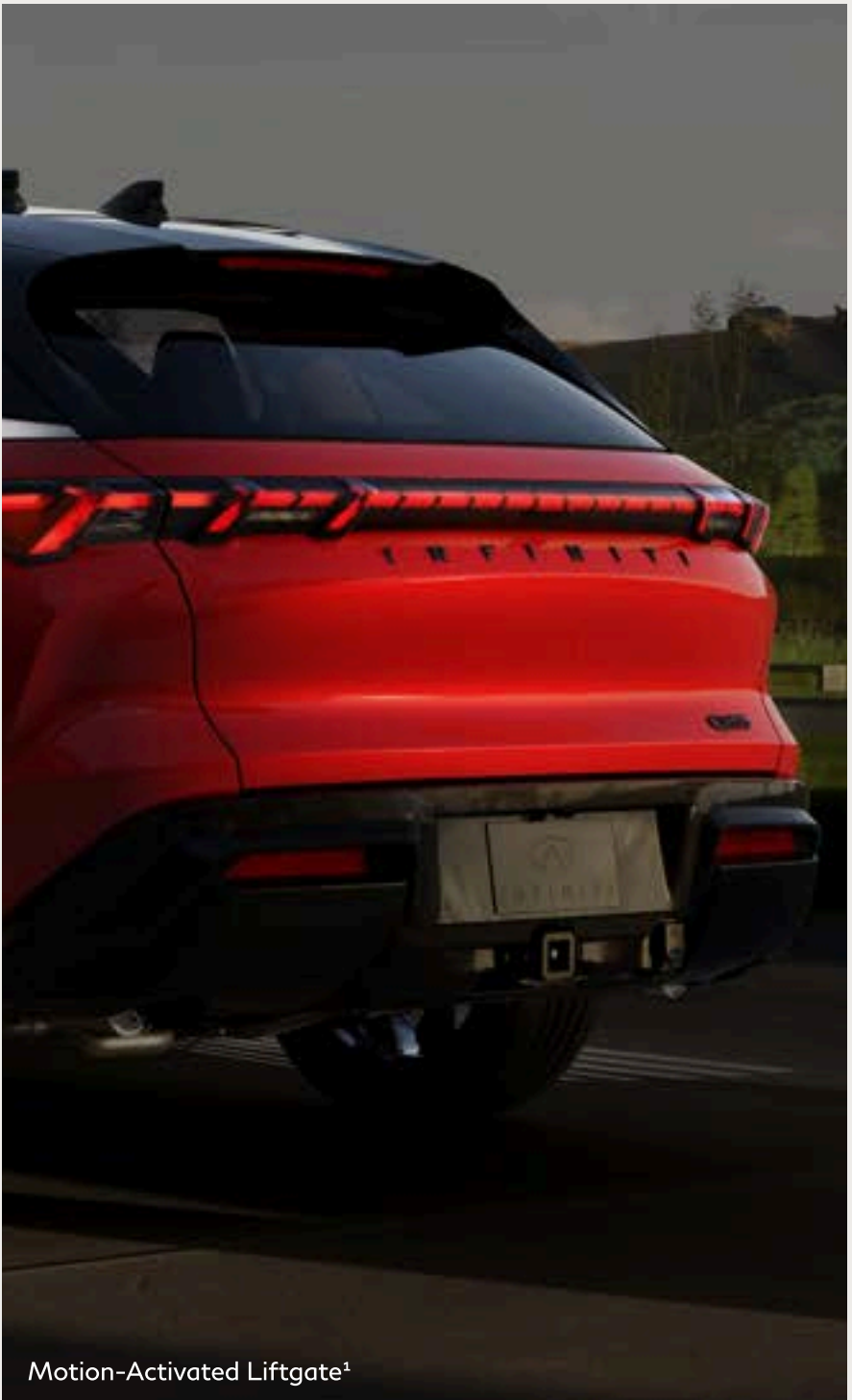

Motion-Activated Liftgate<sup>1</sup>

## SPACIOUS INTERIOR

Flexible enough that your cargo can become what you need it to be, the QX65 offers a spacious **67.7 cubic feet of storage**.<sup>3</sup> When you need the extra space, **power folding rear seats** drop down with the push of a button, transforming the rear of the cabin into an open platform.<sup>3</sup> A **53-liter underfloor storage compartment** provides a discreet space hidden beneath the floor to keep essentials tucked away.

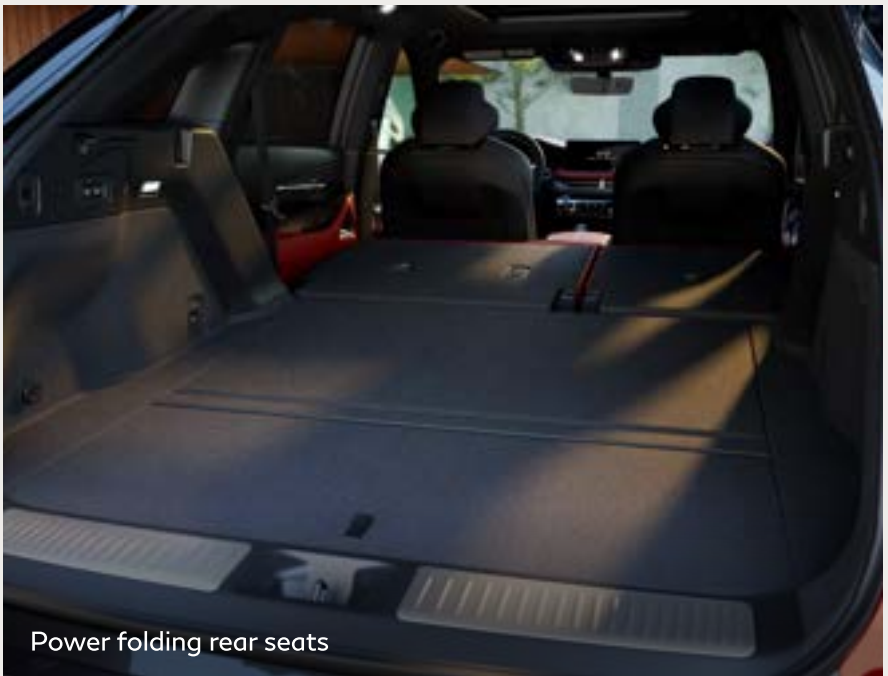

Power folding rear seats



Underfloor storage compartment

# Onboard Tech

Comfort & Convenience



Infotainment



Back to Menu



Build & Price →

QX65

Comfort & Convenience

INTERIOR COMFORT

# Intelligent Comfort



BACK TO SECTION

## INTERIOR COMFORT

Think of your drive home from a busy day as a reservation for relaxation. **Zero Gravity front seats** can help reduce fatigue on long drives, and the available **massaging function**<sup>1</sup> creates a more refreshing ride for the driver and front passenger alike.

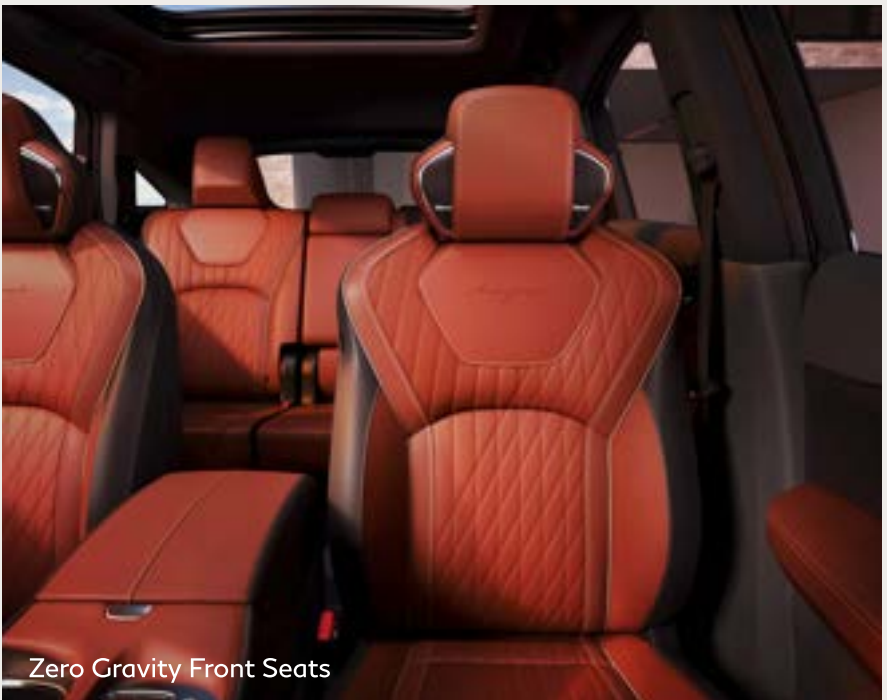

Zero Gravity Front Seats



Massaging Front Seats<sup>1</sup>

## INTERIOR COMFORT

Stay comfortable in every season with **heated and ventilated, climate-controlled front seats**,<sup>1</sup> a standard **heated steering wheel** and **heated outboard second-row seats**<sup>1</sup> for rear passenger warmth.



Heated steering wheel



Climate-Controlled Front Seats<sup>1</sup>

## INTERIOR COMFORT

Each row stays comfortable with the **Tri-Zone Automatic Temperature Control** system, which allows each zone's temperature to be adjusted independently through an intuitive digital display. Rear passengers enjoy full climate control too, with the **Rear-Zone Automatic Temperature Control panel** and **ceiling-mounted rear vents** for more effective cabin cooling. The air in QX65 stays clean as the advanced micro-filter delivers fresher air throughout the cabin with every drive.<sup>5</sup>



Tri-Zone Automatic Temperature Control System with microfilter<sup>5</sup>

QX65

Comfort & Convenience

FORWARD-THINKING FEATURES

Exceptional Is Just a Starting Point



BACK TO SECTION

**FORWARD-THINKING FEATURES**

True luxury remembers. **Steering wheel memory** is available, while every QX65 comes with the standard **dual occupant memory system for driver seat and outside mirrors**. QX65 learns your preferences and recalls them instantly when you hop in. If your co-pilot takes over, the seat and mirrors adjust with a button press. The car simply remembers and honors your individual comfort.



Dual occupant memory system

**FORWARD-THINKING FEATURES**

Your QX65 gets to know you and your specific tastes. The **Intelligent Key** automatically signals the vehicle to personalize as you enter. Easily control your vehicle's locks from a distance with the **approach unlock & walk away lock**. Before you even leave your front door, you can use **Remote Engine Start** to warm up or cool down your vehicle for your drive.<sup>6</sup>



Intelligent Key with Remote Engine Start<sup>6</sup>



Approach unlock & walk away lock

**FORWARD-THINKING FEATURES**

With **acoustic window glass**, strategic placement of advanced sound absorption materials and **Active Noise Cancellation**, QX65 boasts a peaceful drive. Hear less noise from the road, wind and engine, and enjoy easy conversations through the entire cabin. **Active Sound Enhancement** amplifies and refines engine sounds to enhance your driving experience. In SPORT mode, the system delivers a noticeably louder, more spirited growl transforming your acceleration into an audible performance.



Active Noise Cancellation

INTERIOR TECHNOLOGY

Turn Up the  
Brilliance & Amplify  
the Moment



BACK TO SECTION

## INTERIOR TECHNOLOGY

Technology that enhances rather than intrudes guides the design of the QX65's **infotainment displays**. The **Dual 12.3-inch displays** seamlessly integrate navigation, climate, audio, and vehicle controls into a beautiful, intuitive interface.<sup>7</sup> When you need critical driving info without distraction, the **10.8-inch Head-Up Display**<sup>1,8</sup> projects speed limits, turn-by-turn navigation,<sup>9</sup> and incoming alerts directly onto your windshield in your natural line of sight.



## INTERIOR TECHNOLOGY

Klipsch® takes its premium sound system on the road. More akin to a concert hall than a car, the **20 speakers with TriPower® subwoofer** of the **available Klipsch® Reference Premiere Audio System** evenly distribute an immersive **DJX 3D sound** experience. **Dynamic Audio Reveal®** technology helps bring out the emotion and clarity of every note.<sup>1</sup> When a call comes in, the music doesn't have to stop. **Individual Audio**<sup>1,11</sup> directs sound through speakers in the driver's headrest, so the driver hears the phone call while the passengers enjoy uninterrupted music.

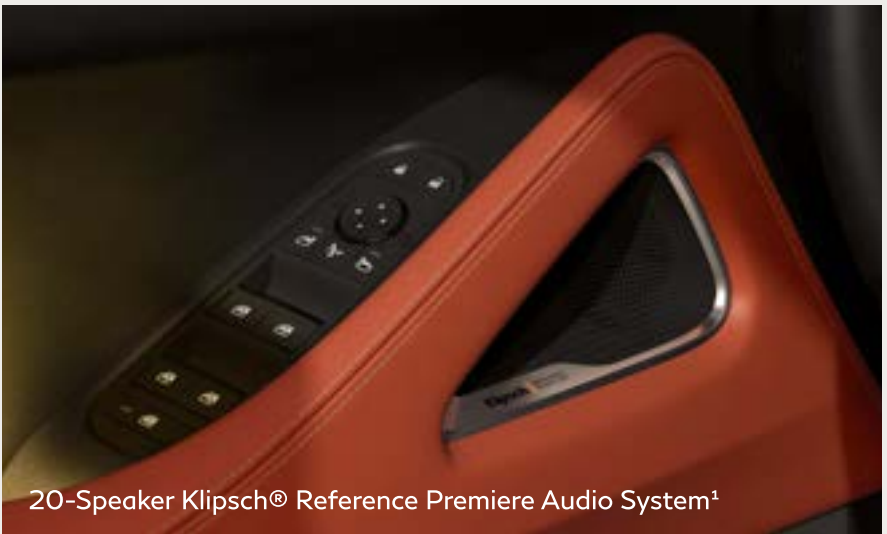

20-Speaker Klipsch® Reference Premiere Audio System<sup>1</sup>



Individual Audio<sup>1,11</sup>

## INTERIOR TECHNOLOGY

The **INFINITI Personalized Sound App**, debuting on the QX65, tailors audio to your unique hearing. Download the app, and a simple sound test will generate a personalized EQ profile to tailor your audio experience. Adjust frequencies with intuitive sliders to hear the difference in real time or simply flip through a quick vibe check. Each driver's profile can have a personalized sound profile.



INFINITI Personalized Sound App



Personalized 10-Band EQ Sound Setting

QX65

Infotainment

INFINITI INTOUCH®

With Google built-in,  
Every Drive Is More  
You



BACK TO SECTION

**INFINITI INTOUCH®**

Pick up where you left off. Your INFINITI with **Google built-in** becomes a natural extension of your compatible smartphone.<sup>10,12</sup> Simply log in with your existing Google Account to access your favorite apps, including **Google Maps**, music and more.<sup>9</sup> Speak to **Google Assistant** to adjust the cabin temperature, set your navigation and respond to texts by speaking as you naturally would. Looking for a specific app? Access the **Google Play store** from the display.

Google built-in<sup>10,12</sup>

Google Play store

**GOOGLE BUILT-IN**

# Just Ask Google

**GOOGLE MAPS**

Becomes your built-in navigation system and integrates across displays so you stay connected and up-to date<sup>9,10,12</sup>

**GOOGLE ASSISTANT**

Google Voice Assistant is your vocal copilot. Control vehicle functions like the seats, heated steering wheel and climate control. To start, just say, "Hey Google"<sup>10,12</sup>

**GOOGLE PLAY**

Includes apps for music, video and messaging, plus – in-park apps like Pluto, Fubo, Prime, and HBO Max are now available to download<sup>10,12,28</sup>

**INFINITI INTOUCH®**

With **unlimited data** and **5G Wi-Fi Hotspot** for up to seven devices, your whole crew can stay connected.<sup>10</sup> QX65 gets automatic **over-the-air updates** that keep the vehicle systems up to date. Use the **MyINFINITI App** on a compatible smartphone to lock/unlock the doors, pre-set the cabin temperature, book scheduled maintenance and more.<sup>10,13,14,15</sup>

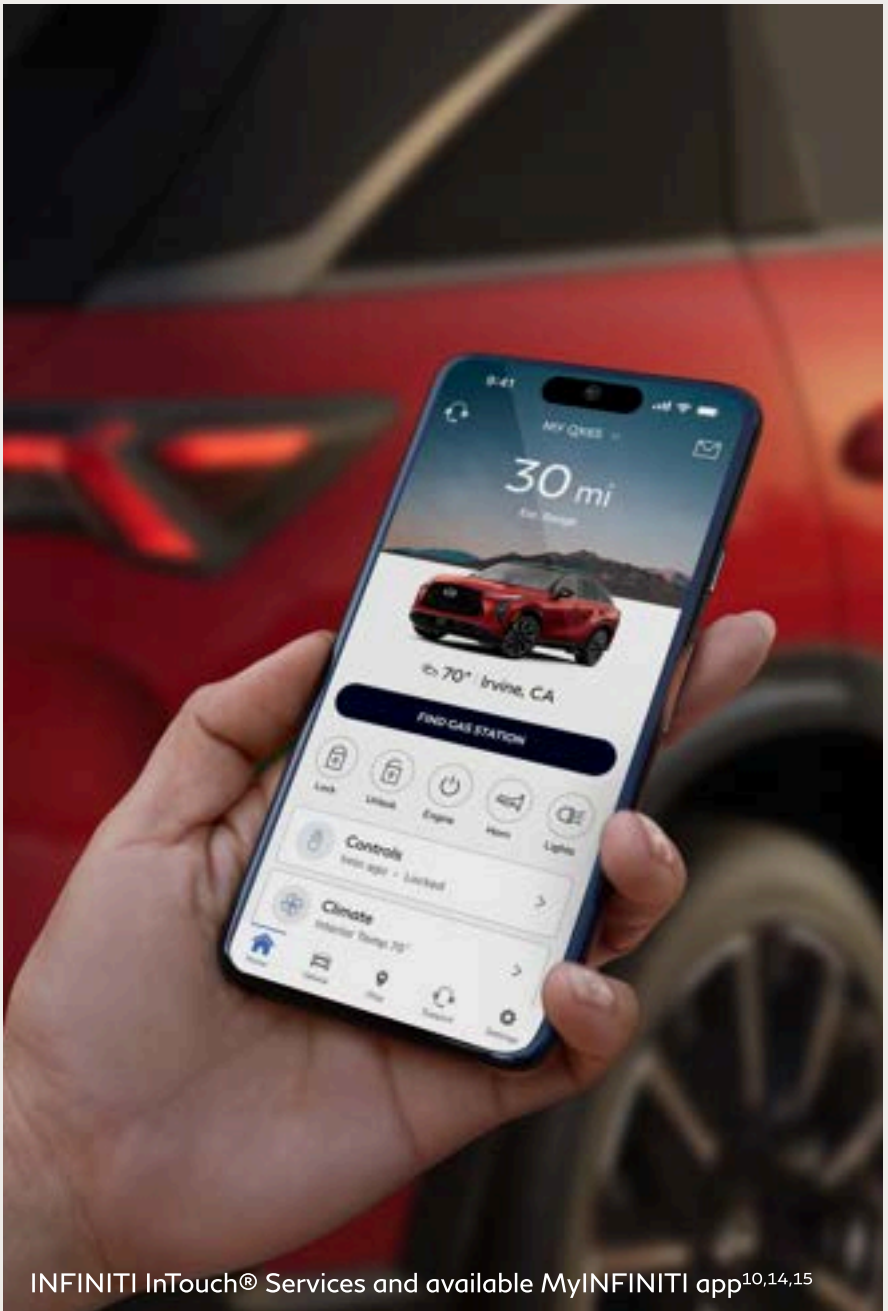

**INFINITI INTOUCH®**

Manage your garage with the **connected garage opener with myQ®**. Plus, enjoy **SiriusXM® with 360L**, which offers curated, ad-free music, sports, news and podcasts.<sup>19</sup>



Connected garage door opener with myQ® (QX65 show)



SiriusXM® with 360L (QX65 show)

CONNECTIVITY

# Stay Present and Connected

USB 1



USB 2

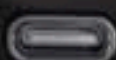

85%



BACK TO SECTION

## CONNECTIVITY

Your smartphone's best apps are conveniently located on the display of your QX65.

Use **wireless Apple CarPlay®** with a compatible iPhone® to stay connected and enjoy hands-free and intuitive touchscreen access to apps like music, navigation, news and more.<sup>9,10,13</sup>

QX65 offers **wireless Android Auto™** too, so you can connect your compatible Android™ device and enjoy hands-free and intuitive touchscreen access to your apps, music, navigation and more – all without the need for cumbersome cables and messy wires.<sup>9,10,13</sup>



Wireless CarPlay® integration<sup>10</sup>



Wireless Android Auto compatibility<sup>10</sup>

## CONNECTIVITY

Powering your life starts with powering your devices, and the QX65 has options for every passenger. The new, industry-leading **Qi2<sup>®</sup> wireless charging pad** with magnetic alignment holds your device perfectly in place, elevating it to protect your cameras and creating optimal contact for charging. 15W fast charging significantly reduces charge time compared to common 5W chargers, while active cooling maintains the ideal temperature for continuous, efficient charging. Combined with **front and rear USB-C charging ports**, there are plenty of ways for everyone's device to stay charged.<sup>13</sup>



Wireless charging pad with magnetic phone holding



Illuminated rear USB-C charging ports

# Performance & Drive Tech

Performance



---

Driver Assist Technology



---

Back to Menu



Build & Price →

QX65

Performance



**TURBOCHARGED PERFORMANCE**

Performance that  
Flexes With You



**TURBOCHARGED PERFORMANCE**

The QX65 is equipped with a **world's first VC-Turbo® engine**<sup>17</sup> offering noticeable **power** and exceptional **efficiency** so you're properly geared up for different needs. Whether you're merging, passing or cruising, the engine's power and efficiency are always ready to make quick, smooth shifts and never leave you waiting.<sup>18</sup> The **sport-tuned acceleration** delivers quicker off-the-line response with **Active Sound Enhancement** that transforms every drive into a more spirited experience.



VC-Turbo engine with 268 horsepower and 286 lb-ft of torque

## TURBOCHARGED PERFORMANCE

With the responsive **sport-tuned 9-speed transmission** and **six INFINITI Drive Modes**, including SPORT, AUTO, ECO, SNOW, TOW and OFF-ROAD, you're ready for almost any road condition. Use the **paddle shifters** to tailor your drive as you desire, and pivot from one destination to the next with purposeful precision.



9-Speed automatic transmission with INFINITI Drive Modes



Paddle shifters

**TURBOCHARGED PERFORMANCE**

Your day is in constant flow, so you need a vehicle that can match your every move. **INFINITI Intelligent All-Wheel Drive** helps you adapt to the conditions of the road at any moment.<sup>1,19</sup>



**TURBOCHARGED PERFORMANCE**

Tow what you need with comfort and confidence. QX65 is capable of towing **up to 6,000 lbs.** standard, when properly equipped. Get available **towing hardware** and **trailer sway control** with the Premium Package on SPORT grade or the Tow and Technology Packages on AUTOGRAPH grade.<sup>20</sup>

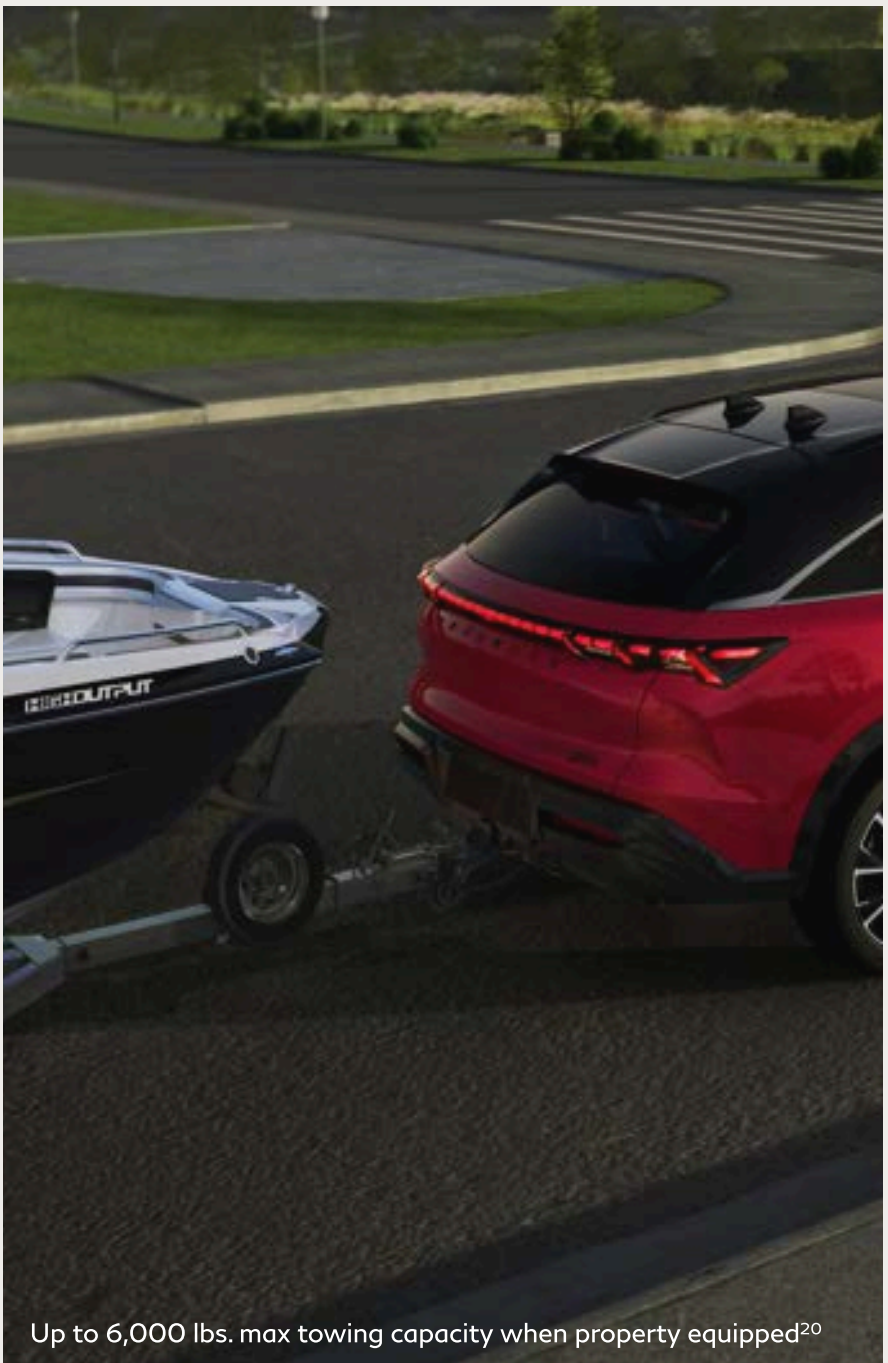

Up to 6,000 lbs. max towing capacity when properly equipped<sup>20</sup>

QX65

Driver Assist Technology

ADVANCED DRIVER ASSISTANCE

# Progress at the Push of a Button



BACK TO SECTION

**ADVANCED DRIVER ASSISTANCE**

Experience the boosted convenience of ProPILOT Assist technology. **ProPILOT Assist** provides hands-on assistance for a smoother highway driving experience, including adaptive **Intelligent Cruise Control with stop-and-go** functionality and **Steering Assist**, which helps keep you centered in your lane.<sup>1,19</sup> Available **ProPILOT Assist 2.1** further advances this technology with **hands-off driving** capabilities (under certain conditions), **Lane Change Assist**, **Passing Assist** and advanced navigation features.<sup>1,9,19,21</sup>

ProPILOT Assist<sup>19</sup>ProPILOT Assist 2.1<sup>1,21</sup>

**ADVANCED DRIVER ASSISTANCE**

Maintain a clear view of the road ahead with **High Beam Assist**. It adjusts automatically between high and low beams based on oncoming vehicles, so you can use your high beams when needed without dazing other drivers. QX65 has your best interest at heart. It even helps alerts you if it detects driver fatigue with a **Driver Attention Alert**.<sup>19</sup>



High Beam Assist

## ADVANCED DRIVER ASSISTANCE

## Vigilance in Action

**PREDICTIVE FORWARD COLLISION WARNING**

Can alert you of a potential collision up to two cars ahead<sup>19</sup>

**FORWARD EMERGENCY BRAKING WITH PEDESTRIAN DETECTION**

Helps watch for vehicles and pedestrians in your path, and if detected, can apply the brakes<sup>19</sup>

**LANE DEPARTURE PREVENTION**

Constantly monitors lane markings and can help guide you back if you unintentionally begin to drift<sup>19</sup>

**BLIND SPOT INTERVENTION®**

Helps alert the driver to vehicles detected in the blind spot area and actively assists you back toward the center of your lane<sup>1,19</sup>

**REAR CROSS TRAFFIC ALERT**

Uses sensors when backing up to detect approaching vehicles from either side and alerts the driver<sup>19</sup>

**REAR AUTOMATIC BRAKING**

Can help apply the brakes if large stationary objects are detected behind you<sup>19</sup>

QX65

Driver Assist Technology

VISIBILITY FEATURES

# Confident Perspective



## VISIBILITY FEATURES

Look to the 12.3" center display for the available **3D Around View® Monitor with Moving Object Detection** that grants you a 360-degree view of the area around your car.<sup>19,22</sup> The nearly **180-degree Front Wide View camera** shows what's around the corner without needing to pull forward.<sup>1,19</sup> Or, if you need to see what's under you, the **Invisible Hood View**<sup>1,19</sup> sees directly under QX65 while in motion, and visualizes the curb, the track at the car wash or a runaway soccer ball on the display.



3D Around View® Monitor with Moving Object Detection<sup>1,19</sup>



Invisible Hood View<sup>1,19</sup>

## VISIBILITY FEATURES

With a flick of the toggle, you can change your available **Smart RearView Mirror** to a wide-angle monitor for an unobstructed digital view of the road behind you. Seamlessly switch between a traditional mirror and high-resolution camera feed for clear visibility, even when passengers or cargo block the rear window.<sup>1,19</sup>



# Style & Specs

Style



Specs



Trims



Back to Menu



Build & Price →

AKANE

# Capturing the Sunrise

INFINITI QX65 in illustrious Sunfire Red. A striking new color that captures a powerful moment when the fiery, rising sun transitions from darkness into light, and the earth awakens. This optical phenomenon is reflected in the Sunfire Red paint. The real gold-coated flecks, immersed in the warm red hue, reveal themselves under changing light, resulting in a resplendent finish that constantly evolves.

[Read More →](#)



Sunfire Red\*



Deep Emerald\*



Graphite Shadow



Mineral Black\*



Moonbow Blue\*



Black Obsidian



Harbor Gray\*



Radiant White\*



Grand Blue\*

INFINITI has taken care to ensure that the digital color swatches presented here are the closest possible representation of actual vehicle colors. Swatches may vary slightly due to viewing light or screen quality. Please see the actual vehicle and colors at your retailer. \*Extra cost option. Contact your local retailer for inventory information.

**INTERIORS 1 OF 3**



Graphite TailorFit® (LUXE)



Stone Gray TailorFit® (LUXE)

INFINITI has taken care to ensure that the digital color swatches presented here are the closest possible representation of actual vehicle colors. Swatches may vary slightly due to viewing light or screen quality. Please see the actual vehicle and colors at your retailer.

INTERIORS 2 OF 3



Graphite TailorFit® (SPORT)



Stone Gray TailorFit® (SPORT)

INTERIORS 3 OF 3



Vermilion Red Semi-aniline Leather appointments (AUTOGRAPH)



Graphite Semi-aniline Leather appointments (AUTOGRAPH)



Stone Gray Semi-aniline Leather appointments (AUTOGRAPH)

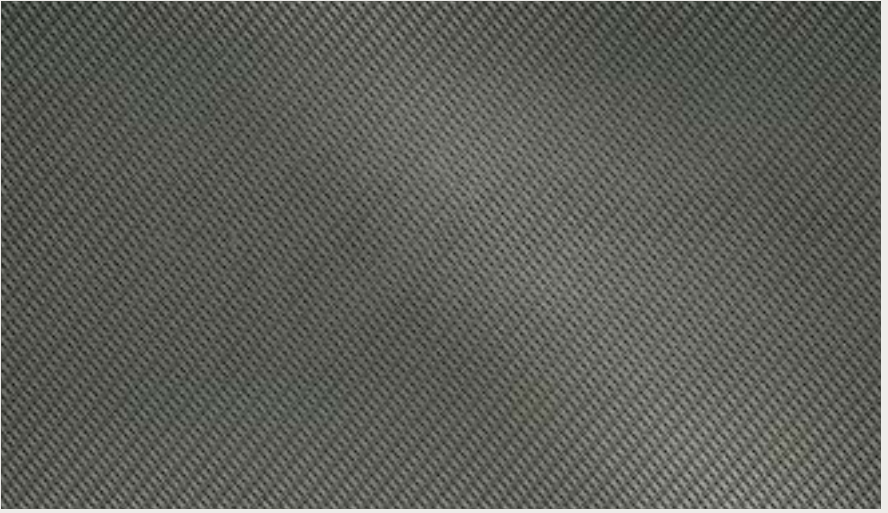

Silver Metallic Weave interior trim (LUXE)

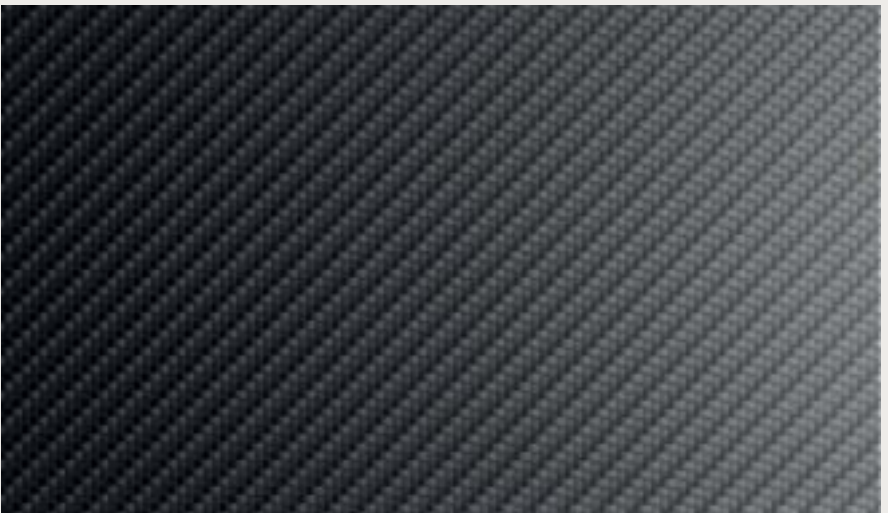

Black Carbonite interior trim (SPORT)



Open Pore Ash Wood interior trim (AUTOGRAPH)



20" machined aluminum-alloy wheels with dark silver finish (LUXE)



20" aluminum-alloy wheels with gloss black finish (SPORT)



21" machined aluminum-alloy wheels with gloss black finish (AUTOGRAPH)

**INTERIOR DIMENSIONS**

---

Head room – first row / second row (inches)  
40.6 / 36.9

---

Leg room – first row / second row (inches)  
44.2 / 35.7

**CAPACITIES**

---

Seating  
5 passengers

---

Interior passenger volume (cubic feet)  
108.4

---

Cargo volume – second row folded flat (cubic feet)<sup>3</sup>  
67.7

---

Maximum tow capacity<sup>20</sup>  
Up to 6,000 lbs. standard, when properly equipped

---

Fuel tank  
18.5 gallons

**POWER & FUEL ECONOMY**

---

Horsepower

268 hp @ 5,600 rpm

---

Torque

286 lb-ft @ 4,400 rpm

---

Estimated fuel economy AWD – city / highway /  
combined (mpg)<sup>18</sup>

20 / 26 / 22

**EXTERIOR DIMENSIONS**

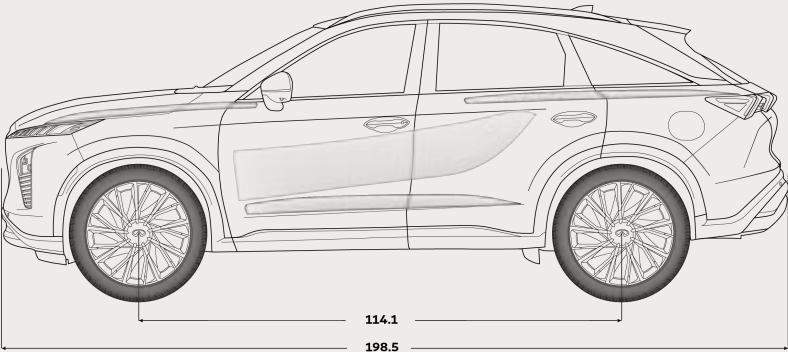
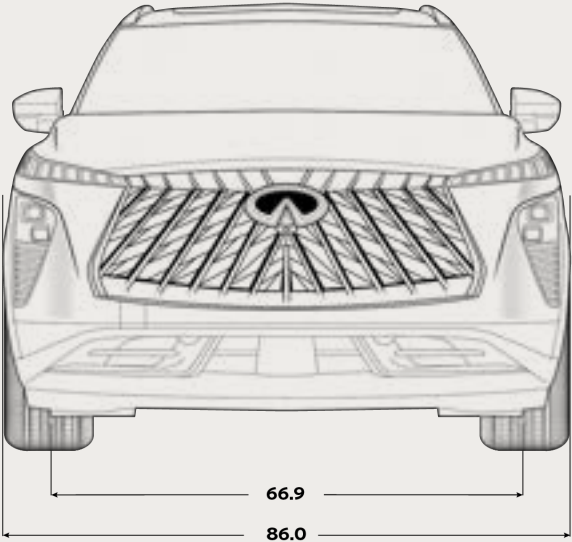

All dimensions are measured in inches.

**EXTERIOR DIMENSIONS**

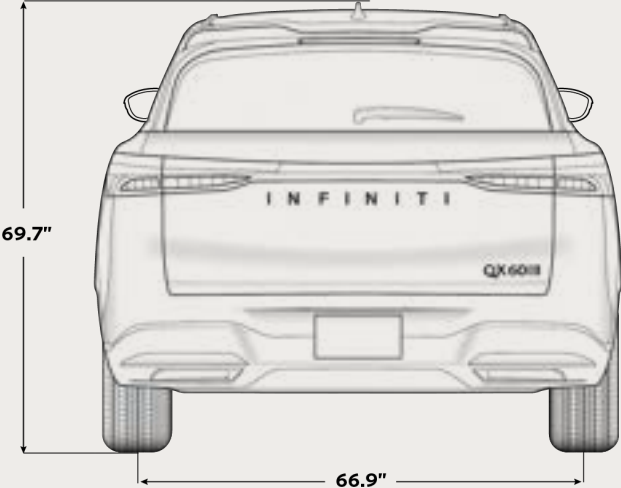

All dimensions are measured in inches.



**QX65 LUXE**

The All-New 2027 QX65



**QX65 SPORT**

Sleek, Blacked-Out Details



**QX65 AUTOGRAPH**

A Balance of Performance and Aesthetics



QX65

# LUXE



Build & Price →



**LUXE 1 OF 7****MECHANICAL & PERFORMANCE**

---

2.0L VC-Turbo<sup>®</sup> 4-cylinder engine (268 hp, 286 lb-ft of torque)

---

Idle stop/start

---

9-speed automatic transmission with manual shift mode

---

Paddle shifters

---

INFINITI Intelligent All-Wheel Drive<sup>19</sup>

---

Drive Mode Selector

---

13.78-inch front ventilated disc brakes / 12.99-inch rear ventilated disc brakes

---

Independent strut front suspension

---

Independent multi-link rear suspension

---

Electric Power Steering

---

Dual exhaust outlets

**EXTERIOR**

---

20" machined aluminum-alloy wheels with dark silver finish and 255/50R20 all-season tires

---

INFINITI Radiant<sup>®</sup> Illuminated Grille Emblem

**LUXE 2 OF 7**

---

LED automatic on/off headlights

---

LED signature Daytime Running Lights

---

LED taillights

---

Gloss black grille surround

---

Gloss black outside mirrors

---

Satin chrome window surround

---

Gloss black body side moldings

---

Panoramic moonroof with power open/close/tilt and sunshade

---

Acoustic front-row window glass

---

Rear privacy glass

---

Power adjustable, auto-fold & heated door mirrors with integrated turn signals, tilt reverse sync & puddle lamps

---

Body-color door handles with capacitive touch sensors on front handles

---

Gloss black roof rails

**LUXE 3 OF 7****COMFORT & CONVENIENCE**

---

TailorFit® seats

---

Leather-wrapped steering wheel

---

Silver Metallic Weave interior trim

---

8-way power adjustable front seats

---

4-way driver and 2-way front-passenger power lumbar

---

60:40-split folding, sliding and reclining second-row bench seat with one-touch release from cargo area<sup>4</sup>

---

2-driver memory system for driver's seat and outside mirrors

---

Heated front seats and steering wheel

---

Tilting and telescoping steering column

---

Tri-Zone Automatic Temperature Control System with microfilter<sup>5</sup>

---

Rear air vents

---

Rear Door Alert<sup>23</sup>

---

Intelligent Key with push button ignition

---

Remote Engine Start<sup>6</sup>

**LUXE 4 OF 7**

---

Approach unlock & walk away lock

---

Traffic Sign Recognition<sup>24</sup>

---

Driver Attention Alert<sup>19</sup>

---

Electronic parking brake with Auto Hold

---

Hill start assist

---

Frameless auto-dimming rearview mirror

---

Graphite headliner

---

Rain-sensing front windshield wipers

---

Hidden rear windshield wiper

---

Power rear liftgate

**INFOTAINMENT**

---

INFINITI 12.3-inch Dynamic Meter Display<sup>7</sup>

---

INFINITI InTouch® 12.3-inch Interactive Display<sup>10</sup>

---

INFINITI InTouch® Package with 3-year trial access<sup>10</sup>

---

Wi-Fi Hotspot<sup>10</sup>

---

Google built-in<sup>10,12</sup>

**LUXE 5 OF 7**

---

Wireless CarPlay® integration<sup>10</sup>

---

Wireless Android Auto™ compatibility<sup>10</sup>

---

Bluetooth® Hands-free Phone System with audio streaming<sup>10</sup>

---

Advanced Voice Recognition

---

HD Radio® Technology

---

SiriusXM® with 360L with 3-month subscription included<sup>16</sup>

---

11-speaker audio system with AM/FM radio

---

Active Noise Cancellation

---

Active Sound Enhancement

---

4 USB-C charging ports<sup>13</sup>

---

Wireless charging pad

---

**DRIVER ASSISTANCE**

---

Cruise control

---

ProPILOT Assist: Steering Assist and Intelligent Cruise Control with full-speed range, stop & hold and auto-resume<sup>19</sup>

---

Predictive Forward Collision Warning<sup>19</sup>

**LUXE 6 OF 7**

---

Forward Emergency Braking with Pedestrian Detection<sup>19</sup>

---

Lane Departure Warning with haptic steering wheel feedback<sup>19</sup>

---

Lane Departure Prevention<sup>19</sup>

---

Blind Spot Warning<sup>19</sup>

---

Blind Spot Intervention<sup>®19</sup>

---

Intersection Assist

---

Rear Cross Traffic Alert<sup>19</sup>

---

Rear Automatic Braking<sup>19</sup>

---

Rear parking sensors

---

RearView Monitor<sup>19</sup>

---

High Beam Assist

**SAFETY**

---

INFINITI Advanced Air Bag System includes dual-stage front air bags with seat belt sensors and an occupant-classification sensor<sup>25</sup>

---

Driver and front-passenger supplemental knee air bags<sup>25</sup>

**LUXE 7 OF 7**

---

Driver and front-passenger seat-mounted side-impact supplemental air bags for outboard occupants<sup>25</sup>

---

Roof-mounted curtain supplemental air bags for side-impact and rollover head protection for outboard occupants<sup>25</sup>

---

LATCH System (Lower Anchors and Tethers for CHildren)

---

Zone Body construction with front and rear crumple zones

---

Tire Pressure Monitoring System with Easy-Fill Tire Alert<sup>26,27</sup>

QX65

# SPORT



Build & Price →



**SPORT 1 OF 2**

Includes All QX65 LUXE Standard Features, Plus:

**EXTERIOR**

---

20" aluminum-alloy wheels with gloss black finish and 255/50R20 all-season tires

---

INFINITI Light Path

---

Sport grille mesh insert

---

Black chrome window surround

---

Gloss black rear emblems

---

"S" badge

**COMFORT & CONVENIENCE**

---

Black Carbonite interior trim

---

Climate-controlled front seats

---

Steering-wheel position memory

---

Power tilting and telescoping steering column

---

Enhanced multi-color ambient interior lighting

---

HomeLink® Universal Transceiver

**SPORT 2 OF 2****INFOTAINMENT**

---

Klipsch® 16-speaker Premium Audio System

**DRIVER ASSISTANCE**

---

Front parking sensors

3D Around View® Monitor with fixed views and Moving Object Detection<sup>19</sup>

Front Wide View<sup>19</sup>

Invisible Hood View<sup>19</sup>

**AVAILABLE PACKAGES** **1****1 PREMIUM PACKAGE**

---

10.8-inch Head-Up Display<sup>8</sup>

Smart RearView Mirror<sup>19</sup>

Motion-Activated Liftgate

Tow hitch member & receiver and 7-pin wiring harness<sup>20</sup>

Trailer sway control

QX65

# AUTOGRAPH



Build & Price →



**AUTOGRAPH 1 OF 3**

Includes All QX65 SPORT Standard Features, Plus:

**EXTERIOR**

---

21" machined aluminum-alloy wheels with gloss black finish and 255/50R20 all-season tires

---

Satin chrome window surround

---

Two-tone exterior roof

**COMFORT & CONVENIENCE**

---

Semi-aniline leather-appointed seats with quilting, perforation, contrast stitching and piping

---

Quilted instrument panel

---

Open Pore Ash Wood interior trim

---

Massaging front seats

---

Premium smooth leather-wrapped steering wheel

---

4-way front-passenger power lumbar

---

Heated rear seats (outboard only)

---

10.8-inch Head-Up Display<sup>8</sup>

---

Smart RearView Mirror<sup>19</sup>

---

Illuminated Kick Plates

**AUTOGRAPH 2 OF 3**

---

Aluminum cargo scuff plates

---

Motion-Activated Liftgate

---

Auto-dimming outside mirror (driver's side only)

**INFOTAINMENT**

---

Klipsch® Reference Premiere Audio System with 20 speakers

---

Individual Audio<sup>11</sup>

**AVAILABLE PACKAGES 1 2****1 TOW PACKAGE**

---

Tow hitch member & receiver and 7-pin wiring harness<sup>20</sup>

---

Trailer sway control

**2 TECHNOLOGY PACKAGE**

---

ProPILOT Assist 2.1 featuring Lane Change Assist, Passing Assist and hands-off driving<sup>21</sup>

---

INFINITI InTouch® Services with 3-year trial access to ProPILOT Assist 2.1<sup>10,21</sup>

---

Driver seat-mounted front-center supplemental air bag<sup>25</sup>

---

**AUTOGRAPH 3 OF 3**

---

Tow hitch member & receiver and 7-pin wiring harness<sup>20</sup>

---

Trailer sway control

# Accessories

Exterior



Interior



Cargo



Lighting/Tech



Towing



Pet



Back to Menu



Build & Price →

QX65

Exterior Accessories

EXTERIOR ACCESSORIES

Equipped for the Big Moments



BACK TO SECTION

**EXTERIOR ACCESSORIES**

Take function to the next level with **Black Roof Rail Crossbars**, that carry up to 165 lbs and make bringing your adventure necessities along a breeze.<sup>3</sup> To carry gear like camping equipment, use an **Affiliated: Yakima® LoadWarrior – Cargo Basket (shown on Crossbars)**.<sup>3,29</sup> It attaches to the crossbars providing a stable and reliable way to carry your gear.



Black Roof Rail Crossbars<sup>3</sup> and  
Affiliated: Yakima® LoadWarrior – Cargo Basket<sup>3,29</sup>

**EXTERIOR ACCESSORIES**

The **Clear Rear Bumper Protector** has a precise fit to help protect your bumper from scratches and scuffs while enhancing your vehicle's appearance. Add **Front and Rear Splash Guards** to reduce dirt spray on lower body panels while helping prevent nicks and scratches caused by road debris.



Clear Rear Bumper Protector



Rear Splash Guards

**EXTERIOR ACCESSORIES**

Helping to keep your wheels out of the wrong hands is simple with **Wheel Locks**. The wheel locks are constructed from hardened steel to increase durability and prevent corrosion. For dark-colored wheels, choose the corrosion-resistant **Dark Lug Nuts and Locks Kit**.



Wheel Locks



Dark Lug Nuts and Locks Kit

QX65

Interior Accessories

INTERIOR ACCESSORIES

# A World of Detail



BACK TO SECTION

**INTERIOR ACCESSORIES**

Custom-made **All-Season Floor Mats – High Wall Liners** help protect the carpet from what the day brings, and they secure in place using a grommet hole/positioning hook system. Enjoy peace of mind with the **Console Net**, which provides a versatile and lightweight solution for securing your everyday items.



All-Season Floor Mats – High Wall Liners

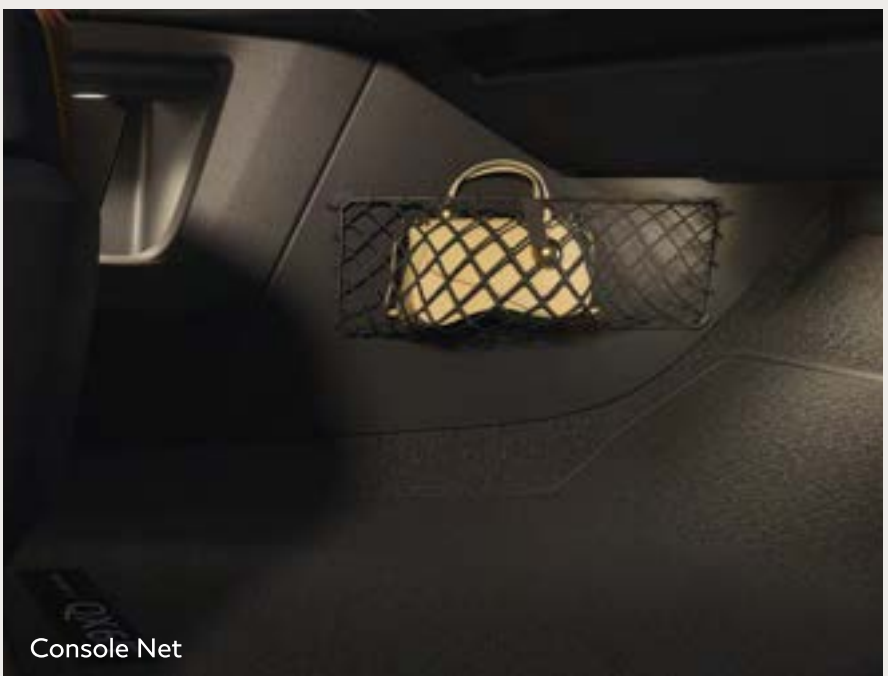

Console Net

**INTERIOR ACCESSORIES**

Keep your cabin uncluttered and intentional with the **Seatback Organizer**. Varying-sized pockets hold everything from pet supplies to small electronics, and the waterproof pocket is easy to wipe clean. Further your cabin's tidiness with a Trash Bin, a sleek and compact accessory that fits in the cup holder and complements your interior.



Seatback Organizer



INFINITI Trash Bin

**INTERIOR ACCESSORIES**

With the INFINITI **Tablet Holder**, second-row passengers can enjoy using their device hands-free – simply attach it to a compatible headrest. And don't forget to protect the floors of your QX65 with custom-fitted **Carpeted Floor Mats**. They lock into place and are easy to remove for cleaning.



Tablet Holder



Carpeted Floor Mats

CARGO CONFIGURATIONS

Your Space,  
Your Rules



BACK TO SECTION

## CARGO CONFIGURATIONS

For privacy and security, use a **Retractable Cargo Cover** to easily block the view of what's stored in the cargo space. The **Reversible Cargo Area Protector** keeps your space clean and helps protect it from scratches and damage. Carrying fragile cargo can be tricky, but with **Cargo Blocks/Stabilizers**, you can secure your precious belongings in the cargo area without worry. The blocks are adjustable and connect to the carpeted side of the **Reversible Cargo Area Protector** to keep items in place.



Retractable Cargo Cover



Cargo Blocks/Stabilizers and Reversible Cargo Area Protector

**CARGO CONFIGURATIONS**

Lastly, reach organization goals with the **Underfloor Storage Dividers (set of 2)**, and the **Cargo Net**. Both are great options for protecting valuables or small belongings by separating them from other belongings in the cargo space.



Underfloor Storage Dividers (set of 2)



Cargo Net

**CARGO CONFIGURATIONS**

Fit more than you think with the **Cargo Organizer**, which features removable dividers that let you customize the space. It secures in place using straps in the cargo area. The **Soft Sided Cargo Cooler** comes in handy, especially on days when you're out and about. Its sleek design features a carbon fiber-patterned vinyl exterior and an insulated, leakproof interior.



Cargo Organizer



Soft Sided Cargo Cooler

**CARGO CONFIGURATIONS**

Extend the comfort of your QX65 into a **Hatch Tent (9' x 9')** covered space with a zippered, adjustable sleeve. Go bigger with the larger **Hatch Tent (10' x 10')** with attached 6' x 7' screen room to transform the tailgate into a family-friendly space.



Hatch Tent (9' x 9')



Hatch Tent (10' x 10')

**CARGO CONFIGURATIONS**

Play it safe with INFINITI Medic, Adventure and Emergency Road Kits, which include all the essential tools to handle the unexpected. The **Medic Kit** is a first-aid bundle in a convenient and durable case with VELCRO® backing to stick to the carpet of your cargo space. The **Adventure Kit** features items such as a mini collapsible shovel, gloves and a tire pressure gauge, while the **Emergency Road Kit** may come in handy with its included flashlight, jumper cables and more.



Adventure Kit



Emergency Road Kit

QX65

Cargo Accessories

AFFILIATED: YAKIMA®

Dust Off That  
Passion



BACK TO SECTION

**AFFILIATED: YAKIMA®**

The **Yakima® LoadWarrior – Cargo Basket** expands your carrying capacity.<sup>3,29</sup> Pair it with the **Yakima® FatCat EVO 6 – Ski Carrier** for winter adventures or the **Yakima® JayLow – Kayak Carrier** for days on the water.<sup>3,29</sup> No tools are needed for install and they'll help keep your gear secure and organized on every journey.



Affiliated: Yakima® FatCat EVO 6 – Ski Carrier<sup>3,29,30</sup>



Affiliated: Yakima® JayLow – Kayak Carrier<sup>3,29,30</sup>

**AFFILIATED: YAKIMA®**

For easy loading and quick access, the lightweight **Yakima® HoldUp 2 – Hitch Mount Bike Rack** secures up to two bikes on the back of the QX65.<sup>3,29</sup> When rooftop real estate is your preference, the **Yakima® FrontLoader – Upright Bike Rack** carries one bike on the roof with a compact footprint that doesn't compromise on stability.<sup>3,29</sup>



Affiliated: Yakima® HoldUp 2 – Hitch Mount Bike Rack<sup>3,29,30</sup>



Affiliated: Yakima® FrontLoader – Upright Bike Rack<sup>3,29,30</sup>

**AFFILIATED: YAKIMA®**

Here's a bike rack that goes long on features and can fit up to two or four bikes. With zero-hassle ZipStrips™, quickly secure bikes with the **Yakima® RidgeBack 2 – Hitch Mount Bike Rack**.<sup>3,29</sup> Need more room? The **Yakima® RidgeBack 4 – Hitch Mount Bike Rack** tilts for easy access to your vehicle and features an anti-sway cradle that eliminates bike-to-bike contact on your drive. When it comes to the **Yakima® OverNOOut MD – Roof Mount Awning**,<sup>29</sup> don't let its low profile fool you. This awning packs small but delivers big. From sideline cheers to ridge line views, it offers excellent protection from the searing sun or sudden showers.

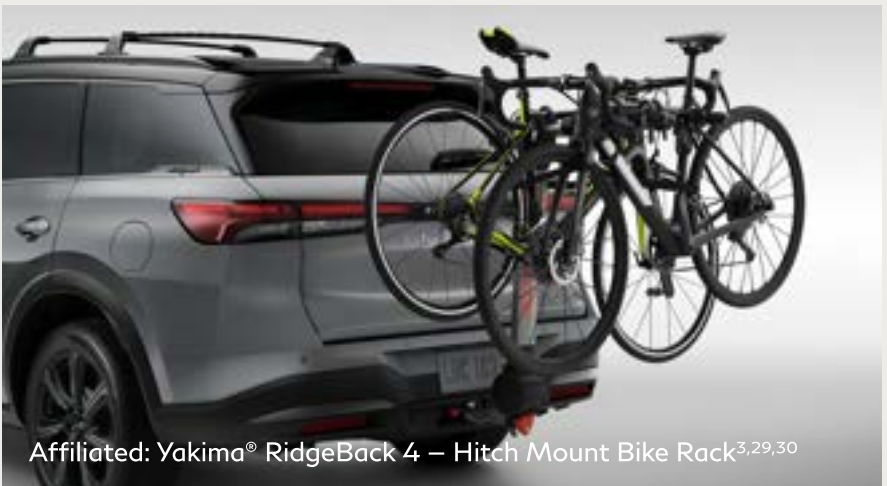

Affiliated: Yakima® RidgeBack 4 – Hitch Mount Bike Rack<sup>3,29,30</sup>



Affiliated: Yakima® OverNOOut MD – Roof Mount Awning<sup>29,30</sup>

**AFFILIATED: YAKIMA®**

No matter what gear your friends show up to your driveway with, you'll be ready with the **Yakima® OffGrid – Cargo Basket**.<sup>3,29</sup> More of a minimalist? The **Yakima® SupDawg – Surfboard Carrier** secures up to two surfboards or stand-up paddle boards up top.<sup>3,29</sup>



QX65

Lighting/Tech Accessories



LIGHTING & TECH

# Signed With a Radiant Signature



BACK TO SECTION

**LIGHTING & TECH**

The **INFINITI Radiant® Black Illuminated Cargo Scuff Plates** brighten, protect and add even more distinction to the cargo area. The **INFINITI Radiant® Black Illuminated Kick Plates** feature a soft-glowing INFINITI logo along the bottom of the front and rear door sills.



**LIGHTING & TECH**

Add to the commanding stance of your QX65 with the **Panoramic Illuminated Headliner**. The premium look gives your drive a little more style and character. Outside, the **INFINITI Radiant® Exterior Welcome Lighting w/ Logo** acknowledges your approach and adds a refined ambience before you even get inside.



Panoramic Illuminated Headliner



INFINITI Radiant® Exterior Welcome Lighting w/ Logo

**TECH & PROTECTION**

Say goodbye to broken and frayed cables with the durable **USB Charging Cable Set** that's designed to keep devices powered up on the go.<sup>13</sup> The **Dual Camera Drive Recorder** captures movement in front of the QX65 and inside of the cabin in the case of an accident or break-in, and it saves the footage so it can be shared for later use.<sup>30,31</sup>

USB Charging Cable Set<sup>13</sup>Dual Camera Drive Recorder<sup>30,31</sup>

## TECH & PROTECTION

Gain an extra sense of assurance with the **Security Impact Sensor**, which sets off an alarm during an attempted window breaking and enhances the QX65 alarm system. A feature that steps up the interior styling of LUXE grade models is the sleek, modern **Frameless Auto-Dimming Rearview Mirror with HomeLink®**. It automatically keeps bright lights out of your eyes and opens the garage door with the press of a button.



Security Impact Sensor



Frameless Auto-Dimming Rearview Mirror w/ HomeLink®

QX65

Towing Accessories

TOWING ACCESSORIES

Spontaneity  
Encouraged



BACK TO SECTION

## TOWING ACCESSORIES

When it comes to road trips, connect and tow with ease by adding INFINITI Towing Accessories for up to 6,000 lbs. standard towing capacity when properly equipped.<sup>20</sup> The **Tow Hitch Receiver, Class III (Hitch Only)** installs on the rear bumper for a seamless look.<sup>20</sup> Pair it with the **Trailer Tow Harness (7-Pin)** to power your trailer lights.



Tow Hitch Receiver, Class III<sup>20</sup>



Trailer Tow Harness (7 Pin)

**TOWING ACCESSORIES**

When properly equipped, pair the **Ball Mount, Class III** with your choice of **Hitch Ball** options—**Class II with 1-7/8" Coupler**, **Class II with 2" Coupler**, or **Class III with 2" Coupler** to configure your system for any adventure.<sup>20</sup>



Ball Mount, Class III<sup>20</sup>



Hitch Ball - Class III (2" Coupler)<sup>20</sup>



PET ACCESSORIES

# Fur Babies On Board



BACK TO SECTION

**PET ACCESSORIES**

Bring your fur family along for the ride. The telescoping **Pet Ramp**, made with a strong yet lightweight aluminum construction, extends up to 64 inches, and the foldable **Pet Carrier** features three mesh doors (top, side and front) with zipper closures. Once you're on the road, the **Pet Seat Protector** helps keep your second-row seats free from fur, and the **Pet Cargo Area Protector** does the same for the cargo space. Lastly, snag a **Dog Harness** – available in four sizes – to secure your dog via a tether to a rear-seat buckle and help limit their movement in the vehicle.

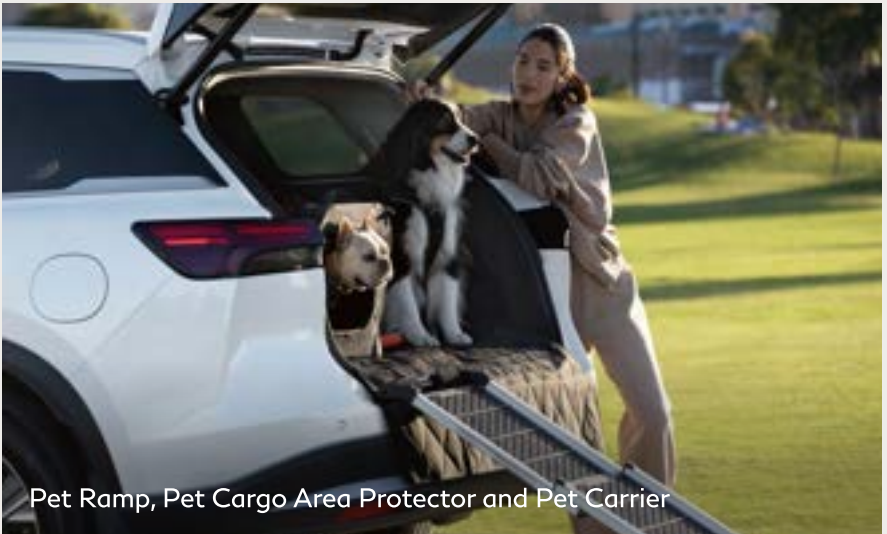

Pet Ramp, Pet Cargo Area Protector and Pet Carrier



Pet Seat Protector and Dog Harness



## INFINITI PREMIUM CARE

# Drive With Confidence

Keeping your INFINITI properly maintained keeps it thoroughly rewarding. That's why to help sustain confidence in your drive and to provide you with added peace of mind in a constantly changing world, each new 2027 INFINITI vehicle includes the INFINITI Premium Care maintenance program that provides up to 3 oil changes and 3 tire rotations for 36 months or vehicle's designated mileage period (whichever occurs first).

Factory-trained technicians use Genuine INFINITI parts to ensure the utmost care, quality and performance. For more information, please visit your local retailer.<sup>32</sup>

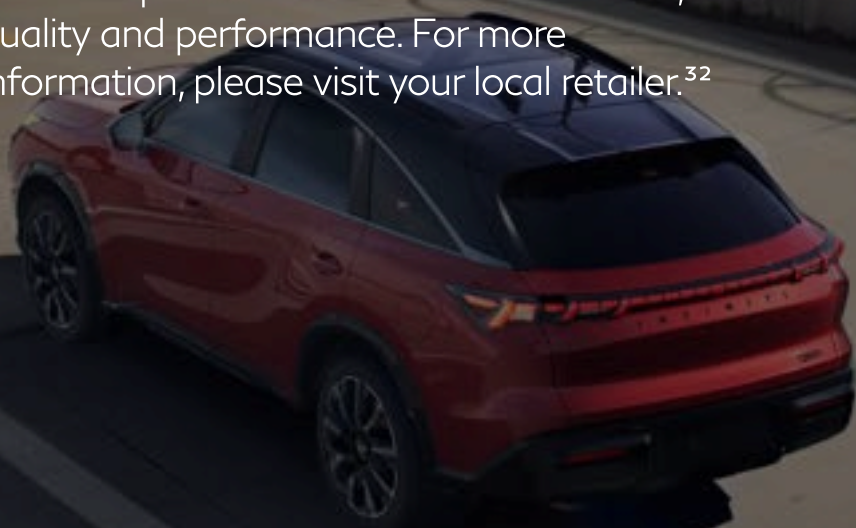



# The Journey Begins

Build an INFINITI that's tailored to your taste and designed around your life.

Build Your QX65 →

JOIN OUR COMMUNITY



1 Feature availability varies by vehicle model year, model, trim level, packaging and options.

2 Extra cost option.

3 Cargo and load capacity limited by weight and distribution. Always secure cargo. Heavy loading of the vehicle with cargo, especially on the roof, will affect the handling and stability of the vehicle.

4 Do not ride in a moving vehicle when the seatback is reclined. For the most effective protection, the seat should be upright. See Owner's Manual for safety information.

5 The Advanced Climate Control System with Plasmacluster® air purifier helps scrub the air in the vehicle's interior. The system senses exterior odors, suppresses unpleasant interior odors, stops the inflow of external odors and helps keep the cabin smelling fresh, but does not always eliminate odors.

6 Remote Engine Start to be used only in accordance with laws or rules in effect in your vehicle's location.

7 Information displayed in image is dependent on how vehicle is equipped. Driving is serious business and requires your full attention. If you have to use the feature while driving, exercise extreme caution at all times so full attention may be given to vehicle operation.

8 Information displayed in image is dependent on how vehicle is equipped. Do not use for extended periods of time. See Owner's Manual for important safety information.

9 Never program while driving. GPS mapping may not be detailed in all areas or reflect current road status.

10 See [www.infiniti.com/intouch/legal](http://www.infiniti.com/intouch/legal) for more INFINITI InTouch features/services information.

11 Available feature. Individual Audio is intended to isolate select audio sources for equipped seating positions, and cannot buffer interior sound. Before using, read Owner's Manual for further information.

12 Feature availability varies by vehicle model year, model, trim level, packaging and options. Consumer activation of a compatible INFINITI InTouch® Services package ("Package") required. Package trial period included with eligible new vehicle purchase or lease. Trial period may be subject to change or termination at any time and without notice. After trial period ends, monthly subscription fee required. Driving is serious business and requires your full attention. Only use features when safe and legal to do so. Never program while driving. GPS mapping may not be detailed in all areas or reflect current road status. Connectivity service required. App subscriptions may be required. Data rates may apply. Subject to third party service availability. Should such service providers terminate or restrict service or features, service or features may be suspended or terminated without notice or with no liability to INFINITI or its partners or agents. Google, Google Play and Google Maps are trademarks of Google LLC. For more information, see [www.INFINITILUSA.com/intouch/legal](http://www.INFINITILUSA.com/intouch/legal).

13 Driving is serious business and requires your full attention. If you have to use the connected device while driving, exercise extreme caution at all times so full attention may be given to vehicle operation. External device not included.

14 Availability may vary. INFINITI InTouch Services subscription may be required. Always read and follow instructions for safe update procedures. You may contact INFINITI at 1-833-283-1886 for assistance with software updates. You may also visit your local INFINITI retailer; retailer charges may apply.

15 MyINFINITI App shown for illustrative purposes only. Feature functionality may vary by vehicle model and options. See MyINFINITI Terms and Conditions.

16 **INFINITI vehicle with "SiriusXM with 360L" capability:** SiriusXM with 360L trial period is included with the purchase or lease of a new INFINITI vehicle if: (i) vehicle is equipped with SiriusXM with 360L capability and (ii) vehicle is purchased or leased from new INFINITI dealer stock. Trial period begins on the purchase or lease date of the qualifying new INFINITI vehicle. SiriusXM with 360L is owned and operated by SiriusXM, use of SiriusXM account and its services and features are subject to the SiriusXM Customer Agreement and Privacy Policy available at [siriusxm.com](http://siriusxm.com), and are not within INFINITI's control. Should SiriusXM terminate, change, or restrict service or features, service or features may be suspended or terminated without notice or with no liability to INFINITI or its partners or agents. INFINITI and its partners or agents are also not responsible for associated costs or other third party changes that may be required for continued operation due to cellular network unavailability, restriction, or termination (including equipment replacements/upgrades, if available, or roaming charges on alternative networks). Trial period is subject to change or early termination at any time without notice. SiriusXM and related logos are trademarks of Sirius XM Radio Inc. and its respective subsidiaries.

**SiriusXM and SiriusXM with 360L Trial Subscription:** Service will automatically stop at the end of your trial subscription period unless you decide to continue service. Trial is non-transferable. If you do not wish to enjoy your trial, you can cancel by calling the number below. All SiriusXM services require a subscription, each sold separately by SiriusXM after the trial period. **Service subject to the SiriusXM Customer Agreement and Privacy Policy, visit [siriusxm.com](http://siriusxm.com) for complete terms and how to cancel which includes online methods or calling 1-866-635-2349.** Some services and features are subject to device capabilities and location availability. Satellite service not available in AK & HI. Certain features and/or content may not be available in vehicles with SiriusXM with 360L unless an active data connection is enabled in the vehicle. Content varies by SiriusXM subscription package. All fees, content and features are subject to change.

17 World's first production variable compression engine launched by Nissan Motor Co., Ltd. in 2018.

18 2027 EPA Fuel Economy Estimates 20 City / 26 Hwy / 22 Combined for LUXE, SPORT, and AUTOGRAPH AWD. Actual mileage may vary with driving conditions. Use for comparison only.

19 Driver-assist and safety features have limitations which affect how they function in certain situations. The driver must never rely exclusively on any vehicle feature to warn about, prevent or lessen the severity of a collision. It is the driver's responsibility to always be in control, monitor the surroundings and safely operate the vehicle. Read your vehicle's Owner's Manual for further information.

20 Towing capacity varies by configuration. See INFINITI Towing Guide and Owner's Manual for additional information. Always secure cargo.

21 INFINITI InTouch Services customer-activated subscription required. See [www.infiniti.com/intouch/legal](http://www.infiniti.com/intouch/legal) for more information. ProPILOT Assist 2.1 cannot prevent collisions. It is the driver's responsibility to be in control of the vehicle and monitor traffic conditions at all times. Hands-off freeway driving is possible when driving in a single lane, on the condition that the driver remains attentive on the road ahead and is prepared to immediately take manual control of the steering wheel when conditions of the road, traffic, and vehicle require it. System operates only when lane markings are detected. Does not function in all weather, traffic and road conditions. System has limited control capability and the driver may need to steer, brake or accelerate at any time to maintain safety. See Owner's Manual for safety information.

22 Virtual composite 360° view.

23 Rear Door Alert System does not detect people or cargo. Always check rear seat before exiting. See Owner's Manual for safety information.

24 Traffic Sign Recognition may not detect and read all traffic signs in all conditions. Driver should monitor all traffic signs and obey all traffic laws. See Owner's Manual for details.

25 Air bags are only a supplemental restraint system. Always wear your seat belt. Rear-facing child restraints should not be placed in the front-passenger's seat. All children 12 and under should ride in the rear seat properly secured in child restraints, booster seats or seat belts according to their size. Air bags will only inflate in certain accidents. See Owner's Manual for safety information.

26 Tire Pressure Monitoring System is not a substitute for regular tire pressure checks. See Owner's Manual for safety information.

27 Vehicle must be on for the Easy-Fill Tire Alert to operate.

28 Use Hands Free Text Messaging when parked in a safe location. If you must use while driving, monitor traffic conditions and keep both hands on the steering wheel to prevent collisions. Compatible device required. Message and data rates may apply.

29 Images shown for illustrative purposes only. Accessories shown on vehicle are not genuine INFINITI parts/accessories. Not warranted by INFINITI. Refer to product manufacturer for warranty details. INFINITI limited warranty does not cover damages or failures to the vehicle caused by improper installation or alterations of any accessory or component. Contact your retailer for details.

30 Vehicle shown is for illustrative purposes only. Not representative of brochure's model year/model.

31 Dual Camera Drive Recorder to be used only in accordance with any laws or rules in effect in your vehicle's location that may apply to audio or video recordings of drivers and passengers.

32 INFINITI Premium Care oil/tire maintenance provided through Elite Protection Program is included with the purchase/lease of a new 2026 or 2027 INFINITI vehicle from retailer stock. Other restrictions apply. **In Florida (License #60128), Missouri, North Dakota, Oregon, and Vermont, INFINITI Extended Services North America is backed by Nissan Extended Services North America, Inc., P.O. Box 685004, Franklin, TN 37068-5004.** Replacement of any part will be made with a new Genuine INFINITI or INFINITI-approved replacement part in use at the time of repair. The replacement part may differ from the original.

Apple CarPlay® and CarPlay® are registered trademarks of Apple Inc. iPhone® is a registered trademark of Apple Inc. All rights reserved. iPhone® or other external device not included. Pairing speed may vary when establishing CarPlay connection wirelessly. Wireless smartphone integration only supported with CarPlay. Bluetooth® word mark and logos are owned by Bluetooth SIG, Inc., and any use of such marks by INFINITI is under license. FUBO is a trademark of FUBOTV MEDIA INC. Google, Android, Android Auto, YouTube Music and other marks are trademarks of Google LLC. Compatible Android phone and compatible active data plan required. To wirelessly use Android Auto on your car display, you need a compatible Android smartphone with an active data plan. You can check which smartphones are compatible at [g.co/androidauto/requirements](http://g.co/androidauto/requirements). HBO MAX is a trademark of Home Box Office, Inc. HD Radio® is a registered trademark of iBiquity Digital Corporation. HomeLink® is a registered trademark of Gentex Corporation. Klipsch® is a registered trademark of Klipsch Group, Inc. myQ® is a registered trademark of The Chamberlain Group, Inc. Pandora® is a registered trademark of Pandora Media, LLC. Plasmacluster® is a registered trademark of the Sharp Corporation. PLUTO is a trademark of Pluto Inc. PRIME VIDEO is a trademark of Amazon Technologies, Inc. Qi® and Qi2® are registered trademarks of Wireless Power Consortium Inc. SiriusXM is a registered trademark of Sirius XM Radio Inc. Velcro® is a registered trademark of Velcro LP Holdings LLC.

This brochure is intended for general descriptive and informational purposes only. It is subject to change and does not constitute an offer, representation or warranty (express or implied) by Nissan North America, Inc. Interested parties should confirm the accuracy of any information in this brochure as it relates to a vehicle directly with Nissan North America, Inc. before relying on it to make a purchase decision. Nissan North America, Inc. reserves the right to make changes, at any time, without prior notice, in prices, colors, materials, equipment, specifications, and models and to discontinue models or equipment. Due to continuous product development and other pre- and post-production factors, actual vehicle, materials and specifications may vary from this brochure. Some vehicles shown with optional equipment. See the actual vehicle for complete accuracy. Availability and delivery times for particular models or equipment may vary. Specifications, options and accessories may differ in Hawaii, U.S. territories and other countries. For additional information on availability, options or accessories, contact your INFINITI retailer or Nissan North America, Inc.

 **BACK TO MENU**